

ROTATING EQUIPMENT SOLUTIONS

PRODUCT CATALOG



Sealing Solutions



Industrial Lubricants
and MRO Chemicals



ARC Efficiency
and Protective Coatings

Providing Complete Solutions Through Innovation and Superior Service

Unparalleled in the Industry

At Chesterton®, we place strong emphasis on working together as partners to provide real solutions. Our high service levels are delivered by combining both industry and product knowledge with experience to implement Best Available Techniques. Our wide geographical reach and local service capabilities enable us to be responsive to your needs.

Reliability through Innovation

To be a full service provider takes a wide array of high quality, engineered sealing products that address your needs. Innovative, high performance products are the core of Chesterton's offerings as a premier sealing solution provider. Some of our standard offerings are:

- Split Seals
- Cartridge Seals
- Gas Seals
- Component Seals
- Pump Packing
- Bearing and Gearbox Protection
- Rotary Seals
- Environmental Controls

Improving Productivity with High Impact Programs

In today's global economy, our clients are faced with increased profitability pressures. Chesterton can assist users in achieving their productivity goals by improving asset reliability and lowering the total cost of ownership. Our programs are easily customized for each plant to:

- Improve equipment availability
- Increase process throughput
- Lower total cost of ownership

Delivering Results for Industry

Meeting industry needs requires a thorough knowledge and understanding of the key drivers specific to a plant. Chesterton's depth of experience allows us to deliver results such as:

- Increased equipment reliability
- Reduced water consumption
- Reduced environmental emissions
- Increased energy efficiency





TABLE OF CONTENTS

Sealing Solutions for Rotating Equipment

- Mechanical Seals** 06
 - Split Seals 06
 - Environmental Controllers 07
 - Gas Seals 08
 - Cassette Seals 09
 - Cartridge Seals 09
 - Slurry Seals 11
- Pump Packing** 12
 - General Service 12
 - Slurry/Abrasive 14
 - Food Grade 15
 - Injectable 16
 - Chemical 16
 - Marine 17
 - Graphite 18
 - Carbon 19
- Bearing and Gearbox Protection** 19
- Viscous Fluids and Dry Powders** 20

ARC Efficiency and Protective Coatings

- Erosion Resistant Coatings for Metals 25
- Coatings for Corrosion, Erosion, and Chemical Attack for Metals 26
- Thin Film Coatings for Concrete 28
- Abrasion Resistant Coatings for Metals 29

Industrial Lubricants and MRO Chemicals

- Lubricants and Greases** 30
 - Liquid Lubricants 31
 - Greases 31
 - Lubricant Dispensers 32
 - Thread Lubricants/Anti-seize 33
- Maintenance Specialties** 34
 - Penetrating Oils 34
 - Thread Sealing 34
 - Flange Sealing 35
- Cleaners and Degreasers** 35
 - Water-based Alkaline Cleaners 35
 - Water-based Acid Cleaners 37
 - Solvent-based Cleaners 37
- Corrosion Control** 38
 - Corrosion Control 38
 - NSF Registered Products 39

Chesterton® Solutions for Rotating Equipment

Whether advanced shaft sealing, gearbox protection or protective coatings, Chesterton provides the total solution for improved pump reliability.

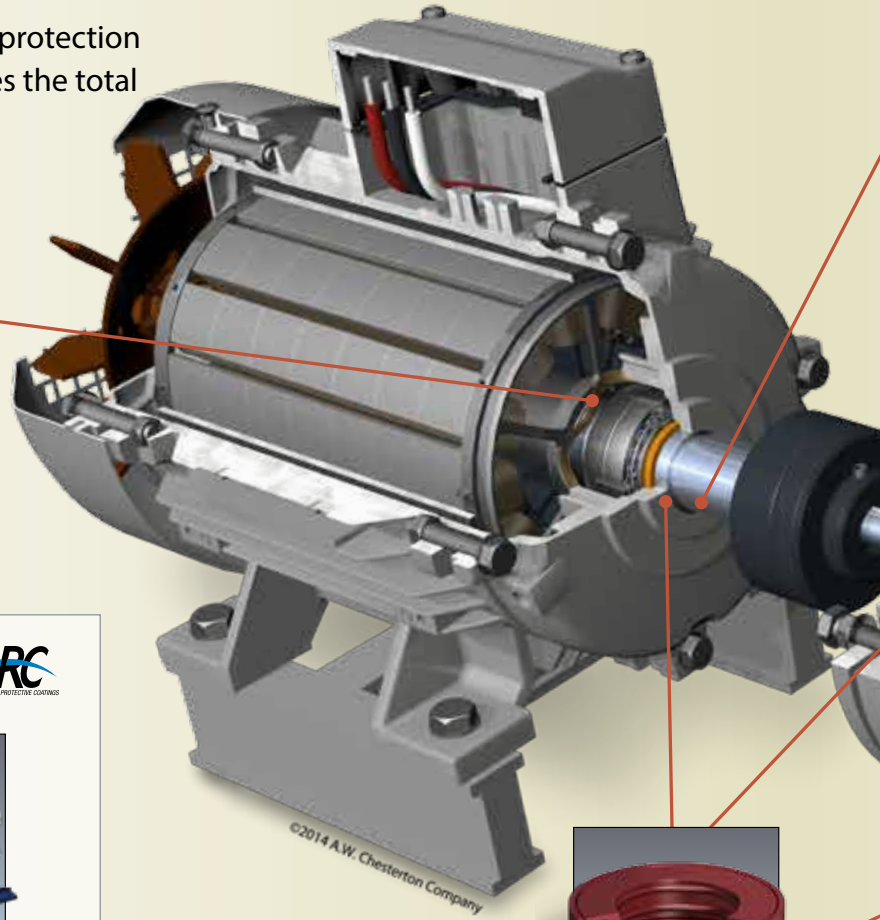

Advance Lubrication Technology

Chesterton's QBT technology. Extends bearing life. Resists wear, load and corrosion.

Other ARC Efficiency & Protective Coatings Products



Machinable Composite
Rebuild and protect worn shafts



Protective Coating for Concrete & Metals
Protect pump base plate, frame and pump base

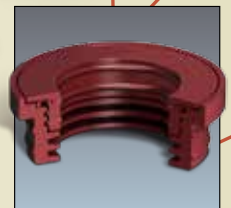

Polymer Labyrinth Seal
Labyrinth seal for pumps, motors, and gearboxes

Other Maintenance and Repair Products



Best Penetrating Oil.
Excellent for hard to reach areas where rust, tar, grease and dirt may prevent easy removal of nuts, bolts and fittings.



Anti-seize
Prevent rust and seizure bolts and prevent fretting and corrosion while securing bearings



Thread Sealing
High performance PTFE tapes and paste



Gasketing
Make any size gasket with Moldable Polymer Gasketing

©2014 A.W. Chesterton Company



Automatic Microprocessor Controlled Dispensing System
Delivers precise volumes of lubricant. Simple to use and install.

Bearing Protection
Protect the bearing housing with high performance bearing seal

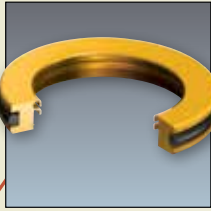

Split Seals
Superior performance with easy installation

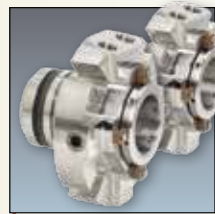
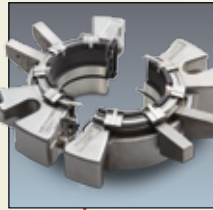

Cartridge Seals
Upgrade seal performance with Single Cassette Seals or S20 Dual



Pump Packing
Reduce maintenance cost and sleeve wear

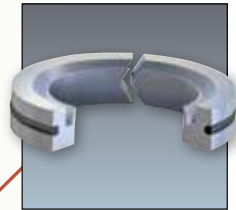

Restriction Bushings
Protect the stuffing box and reduce the flush rate

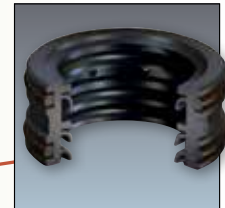

Stuffing Box Sealing
High reliability stuffing box sealing solutions for high viscosity fluids and powders



Protective Coatings for Metals
Rebuild, restore and coat impeller vanes and volute



Environmental Controls
Eliminate abrasive particles in the stuffing box and extend seal and packing life



SuperSet
Upgrade to the enhanced packing system to extend equipment life

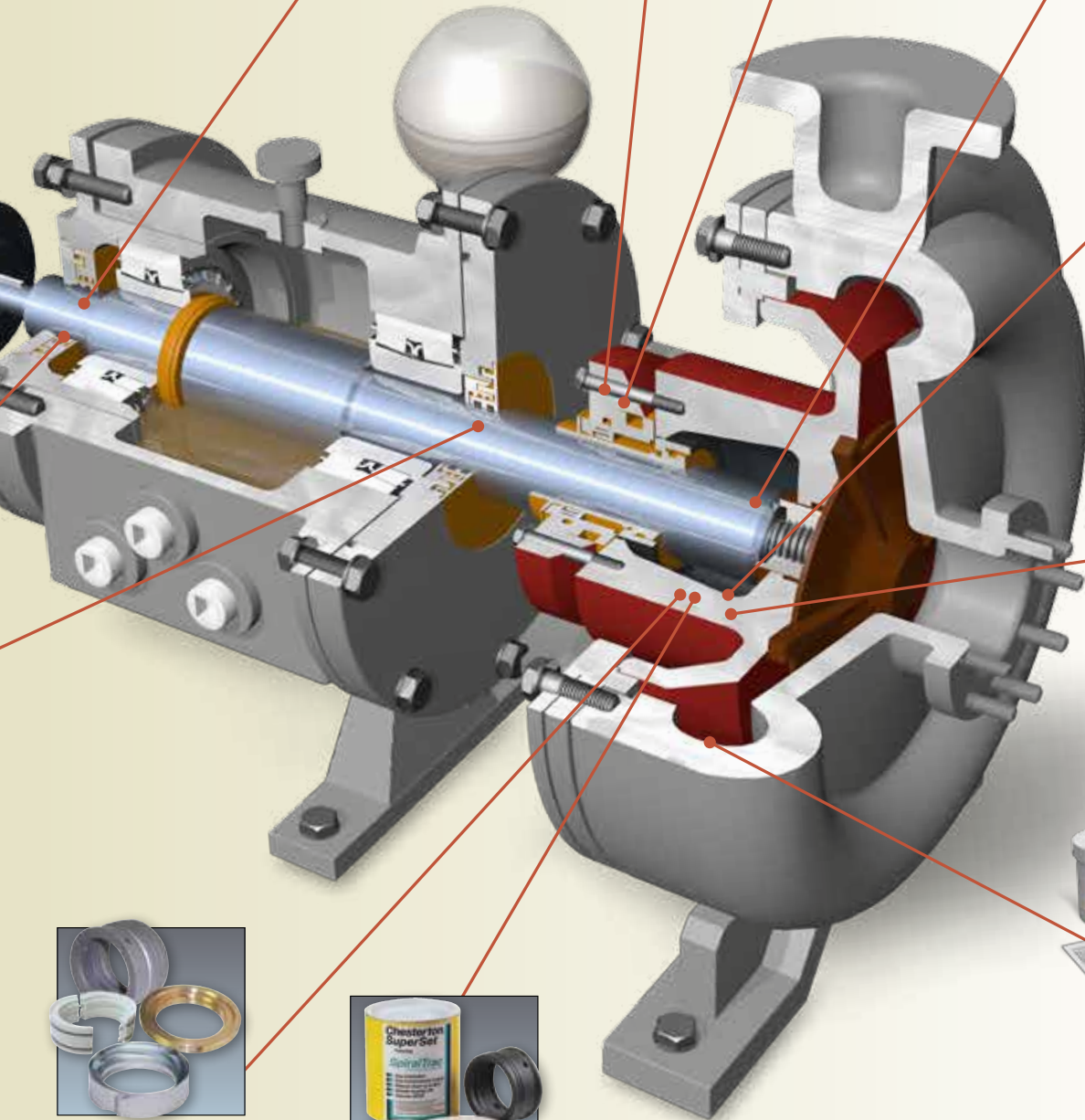

442C™

Cartridge Split Mechanical Seal

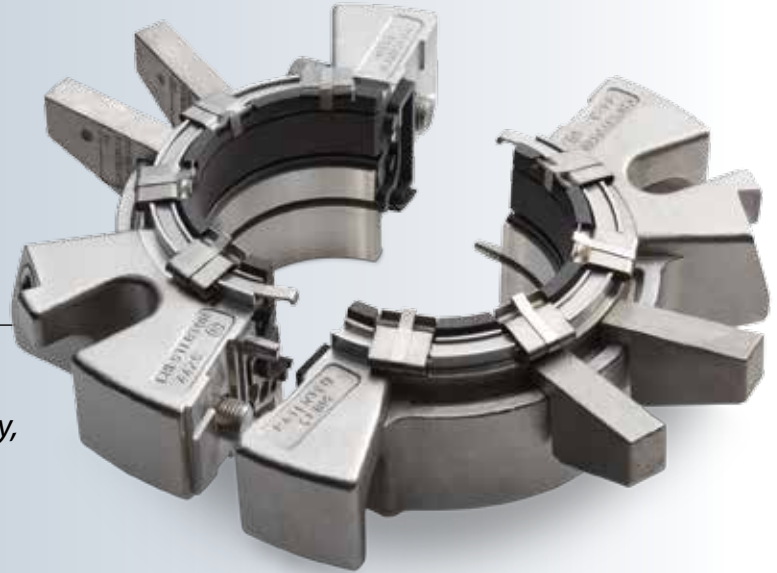

The 442C™ Cartridge Split Mechanical Seal is the latest innovation in split seal technology, combining superior performance with the ease-of-installation of a cartridge split seal.

Operating Conditions		Materials	
Sizes	25 mm to 120 mm (1.000" to 4.750")	Faces	CB, CER, RSC
Pressure*	710 mm or 28" Hg Vacuum to 30 bar g (450 psig)	Elastomers	FKM, EPDM, FEPM
Temperature	120°C (250°F)	Metals	1.4401 (316SS)
Speed	20 m/s (4000 fpm)	Springs	Elgiloy®

ATEX Category I, Group 2 Approved, Fits ISO-3069, ACS Approved

*Seal pressure capabilities are dependent on the fluid sealed, temperature, speed, and seal face combinations.

- Simple cartridge installation—without equipment disassembly
- Innovative design with superior performance
- Fits the majority of rotating equipment
- Easy field repair

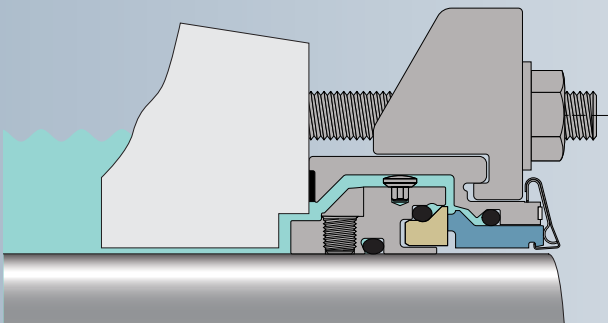

Support Products



442M
Split Mixer Seal

The mixer version of the standard split seal that accommodates large radial and axial shaft motion associated with mixers, agitators, reactors, and blenders.



442PR
Split Pumping Ring Seal

The high-capacity pumping ring provides for maximum heat removal and reliability in hot water services such as heater drain and boiler feed pumps.

Elgiloy® is a registered trademark of Elgiloy Specialty Metals.

SpiralTrac™

Environmental Controllers

When used with Chesterton mechanical seals, SpiralTrac™ Environmental Controllers greatly enhance seal reliability by effective removal of solids and improved cooling of the stuffing box.



Versions	
F (Split)	Greatly reduced flush
N	Reduced/No flush in no fibrous fluids
D	Reduced/No flush in fibrous fluids
P (Split)	Packing version
C	With drain for crystallizing media

Available Materials
1.4401 (316SS)
416 SS
PTFE – Glass Filled
PTFE – Carbon Graphite Filled
Bronze
Ti/EN 3.7035
AWC800 – Red Polymer
Monel® K400 / EN 2.4360

- Extends seal reliability in most rotating equipment applications
- Reduces cost of flushing in abrasive applications
- Fits all rotating equipment

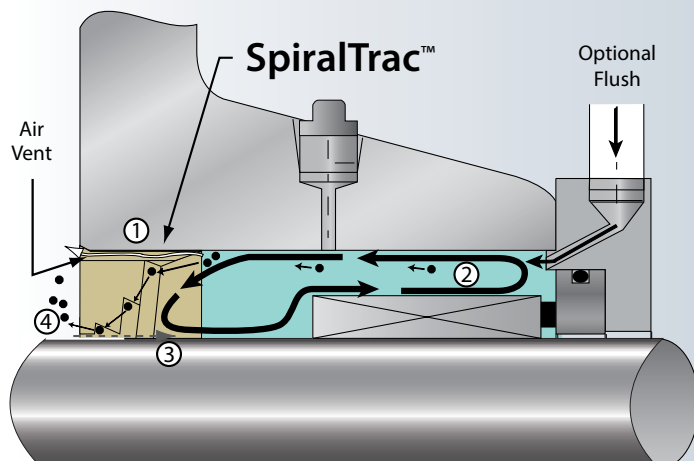

- 1 Air**
Vented from cavity when pump is stationary (eliminates crystallization, coking overheating due to air)
- 2 Circulation**
Driven around seal (excellent face cooling)
- 3 Exchange**
In and out of cavity (heat removed from cavity)
- 4 Particulate**
Immediately removed from cavity through the exit groove, flush or no flush

Configurations Available

Split

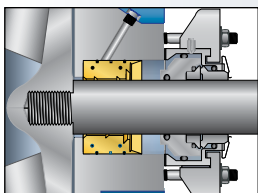

Adapter

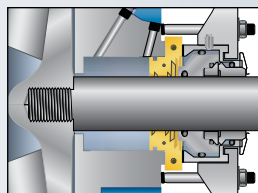

Standard

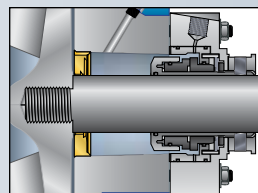

Packing

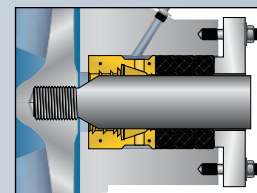

SpiralTrac™ is a trademark of EnviroSeal Engineering Products Ltd.
Monel® is a registered trademark of Special Metals Corporation.

4400

Dual Concentric Gas Seal

Advanced technology made simple in a gas seal design. The 4400 is a seal for all purposes and provides for an easy gas seal upgrade option. It is an ideal choice for upgrading under-performing, liquid lubricated seals to high performance, non-contacting operation.

Operating Conditions		Materials	
Sizes	25 mm to 90 mm (1.00" to 3.625")	Faces	CB, SSC
Pressure	711 mm or 28" Hg Vacuum to 20 bar g (300 psig)	Elastomers	FKM, EPDM, FEPM, ChemLast™
Temperature	-55°C to 300°C (-67°F to 570°F)	Metals	1.4401 (316SS)
Speed	25 m/s (5000 fpm)	Springs	2.4819 (Alloy C-276)

Fits ISO-3069-C

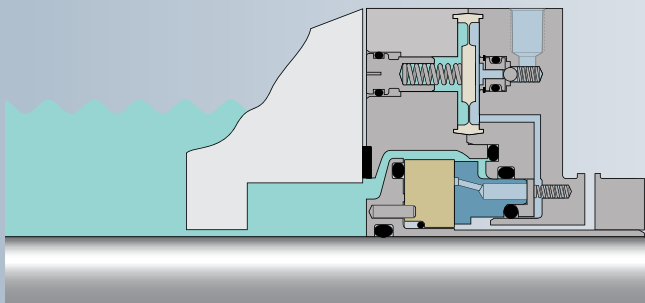

- Delivers low cost-of-ownership for a broad range of applications
- Advanced technology that is easy to install and operate
- Exclusive In-Gland Control System eliminates the need and expense of an external gas panel

Compact Design for Greater Equipment Fit

The 4400 has been designed to fit popular process equipment including ANSI and API process pumps, top entry mixers, blowers, and compressors without equipment modification. Besides the obvious fitting and installation benefits, this also makes Chesterton gas-sealing technology available for a wider range of applications. Costly equipment modification is avoided.

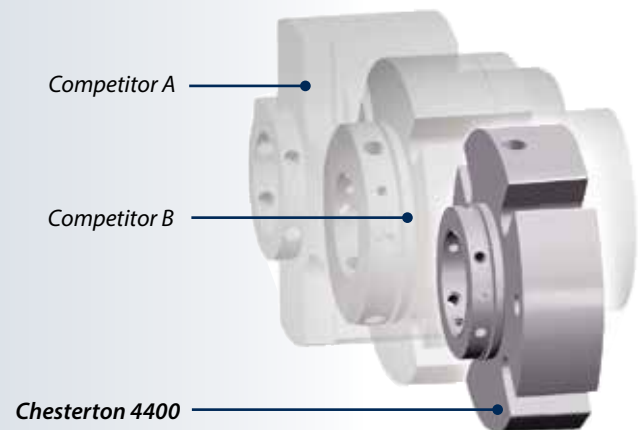

MECHANICAL SEALS

S10

High Performance Single Cassette Seal

A unique modular cassette that combines advanced seal technology with flexibility in maintenance and repair.

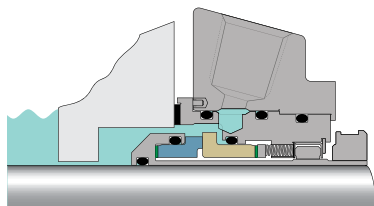

Operating Conditions		Materials	
Sizes	25 mm to 120 mm (1.00" to 4.75")	Faces	CB, SSC, TC
Pressure	711 mm or 28" Hg Vacuum to 31 bar g (450 psig)	Elastomers	FKM, EPDM, FEPM, ChemLast™
Temperature	-55°C to 300°C (-67°F to 570°F)	Metals	1.4401 (316SS)
Speed	25 m/s (5000 fpm)	Springs	2.4819 (Alloy C-276)

Fits ISO-3069, ASME B73.1, B73.2



- High performance sealing
- One optimized sealing concept for plant-wide standardization
- Easy to maintain

S20

High Performance Dual Cassette Seal

A unique modular cassette that combines advanced seal technology with flexibility in maintenance and repair.

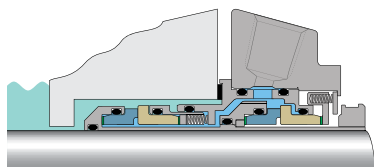

Operating Conditions		Materials	
Sizes	25 mm to 120 mm (1.00" to 4.75")	Faces	CB, SSC, TC
Pressure	711 mm or 28" Hg Vacuum to 31 bar g (450 psig), 17 bar g (250 psig) inboard differential	Elastomers	FKM, EPDM, FEPM, ChemLast™
Temperature	-55°C to 300°C (-67°F to 570°F)	Metals	1.4401 (316SS)
Speed	25 m/s (5000 fpm)	Springs	2.4819 (Alloy C-276)

Fits ISO-3069, ASME B73.1, B73.2



- Advanced sealing performance
- One optimized sealing concept for plant-wide standardization
- Easy to maintain

150

General Purpose Cartridge Single Seal

Designed for baseline applications and for upgrading packed or component-sealed equipment—this seal is a value leader in its class.

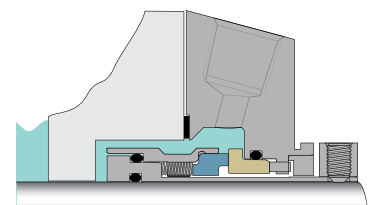

Operating Conditions		Materials	
Sizes	25 mm to 120 mm (1.00" to 4.75")	Faces	CB, SSC
Pressure	711 mm or 28" Hg Vacuum to 20 bar g (300 psig)	Elastomers	FKM, EPDM, FEPM, ChemLast™
Temperature	-55°C to 300°C (-67°F to 570°F)	Metals	1.4401 (316SS)
Speed	20 m/s (4000 fpm)	Springs	2.4819 (Alloy C-276)

Fits ISO-3069, ASME B73.1, B73.2, ACS Approved



- Simple upgrade to reduce plant maintenance costs
- Reliable cartridge design that increases seal life

250

General Purpose Cartridge Dual Seal

Designed for cost-effective upgrading from packing and under-performing single seals—this seal is a value leader in its class, further increasing plant reliability.

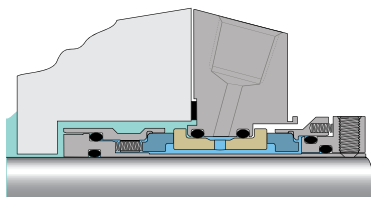

Operating Conditions		Materials	
Sizes	25 mm to 120 mm (1.00" to 4.75")	Faces	CB, SSC
Pressure	711 mm or 28" Hg Vacuum to 20 bar g (300 psig), 10 bar g (150 psig) outboard	Elastomers	FKM, EPDM, FEPM, ChemLast™
Temperature	-55°C to 300°C (-67°F to 570°F)	Metals	1.4401 (316SS)
Speed	20 m/s (4000 fpm)	Springs	2.4819 (Alloy C-276)

Fits ISO-3069, ASME B73.1, B73.2



- Provides sealing security that conventional single seals cannot match
- Reliable cartridge design that increases seal life

180™

Heavy Duty Single Seal

A compact chassis designed with ease of use and no modification. Advanced design features yielding "next step" single seal technology.

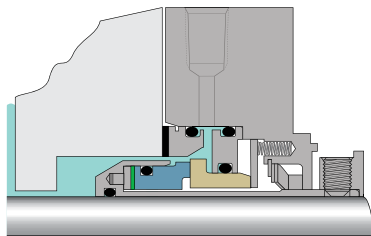

Operating Conditions		Materials	
Sizes	25 mm to 120 mm (1.00" to 4.75")	Faces	CB, SSC, TC
Pressure	711 mm or 28" Hg Vacuum to 40 bar g (600 psig) outboard	Elastomers	FKM, EPDM, FEPM, ChemLast™
Temperature	-55°C to 300°C (-67°F to 570°F)	Metals	1.4401 (316SS)
Speed	25 m/s (5000 fpm)	Springs	2.4819 (Alloy C-276)

Fits ISO-3069, ASME B73.1, B73.2



- Maximum performance for demanding, high-torque applications
- Reliable sealing of slurries
- Suited for the broadest range of applications

280™

Heavy Duty Cartridge Dual Seal

A dual seal design for severe duty and greatest reliability in difficult applications—including mixers and agitators*.

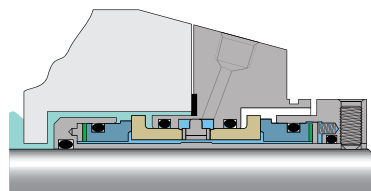

Operating Conditions		Materials	
Sizes	25 mm to 120 mm (1.00" to 4.75")	Faces	CB, SSC, TC
Pressure	711 mm or 28" Hg Vacuum to 40 bar g (600 psig), 17 bar g (250 psig) outboard	Elastomers	FKM, EPDM, FEPM, ChemLast™
Temperature	-55°C to 300°C (-67°F to 570°F)	Metals	1.4401 (316SS)
Speed	25 m/s (5000 fpm)	Springs	2.4819 (Alloy C-276)

Fits ISO-3069, ASME B73.1, B73.2, ATEX Category I, Group 2 approved

*Extended motion capability available in 280M version.



- High-reliability sealing
- Maximum solids handling capability
- Superior performance for demanding applications
- Motion tolerant for mixer applications*

170

Slurry Cartridge Single Seal

Engineered to operate in harsh, heavy consistency slurry environments and to eliminate costly external seal flushes in the majority of applications.

170 ISO is an off-the-shelf product that fits directly to ISO-3069-H and ISO-3069-C seal chambers.

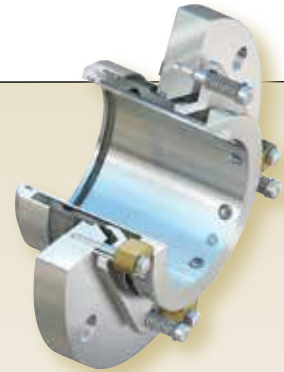
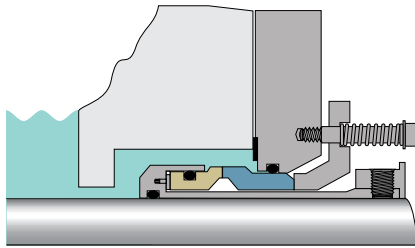

- Runs longer in heavy abrasive slurries without the need for flush or quench water
- Reliable design that deals with real life slurry pumping conditions
- Easy to maintain

Operating Conditions		Materials	
Sizes	25 mm to 228 mm (1.00" to 9.00")	Faces	SSC, TC
Pressure	711 mm or 28" Hg Vacuum to 17 bar g (250 psig)	Elastomers	FKM, EPDM, FEPM, ChemLast™
Temperature	-55°C to 300°C (-67°F to 570°F)	Metals	1.4401 (316SS)*
Speed	11 m/s (2200 fpm)	Springs	2.4819 (Alloy C-276)

*Duplex stainless steel available as an option.

Intelli-Flow™ HT

Water Saver

Features a thermally activated valve that automatically drains hot barrier fluid (only when necessary) to keep dual seals running cool and reliable. Valve opening temperature preset to work with S20 Seals.

Operating Conditions	
Pressure	20 bar g (300 psig)
Temperature	125°C (250°F)
Temperature set point	80°C (176°F)
Connections	1/4 NPT
Materials	1.4401 (316SS)



- Clean in place
- Maintenance-free
- Easy to install
- 95% water savings compared to open barrier fluid supply

GENERAL SERVICE

1730

General Service Packing

Durable performance packing that is easy to install and will not score shafts.

Technical Data	
Materials	Thermoset fibers with lubricants and blocking agents
Applications	Water pumps, paper stock pumps, slurries, agitators, mixers
Pressure	28 bar g (400 psig)
Speed	10 m/s (2000 fpm)
Temperature	290°C (550°F)
Chemical Resistance	pH 1 to 13



- Easy and fast break-in
- Abrasion resistant, while non-scoring
- Good chemical resistance
- Good temperature resistance

1730SC

Withstands Radial Shaft Motion and Vibration

Durable, thermoset polymer that's easy to install and won't score shafts, with an elastic rubber core to maintain leakage control when faced with radial shaft motion and vibration.

Technical Data	
Materials	Thermoset fiber with resilient silicone rubber core
Applications	Agitators, mixers, blenders, washers and pulpers
Pressure	28 bar g (400 psig)
Speed	10 m/s (2000 fpm)
Temperature	230°C (450°F)
Chemical Resistance	pH 2 to 12



- Easy and fast break-in
- Durable, yet non-scoring
- Withstands radial shaft motion and vibration

1727

Multi-Lon®

A synthetic packing designed to deliver performance equal to synthetics but with the pliability of asbestos.

Technical Data	
Materials	Continuous, synthetic thermoset fibers impregnated with PTFE and a silicone-free break-in lubricant
Applications	Water, steam, and chemical pump applications in pulp, paper, and chemical plants
Pressure	15 bar g (200 psig)
Speed	10 m/s (2000 fpm)
Temperature	255°C (488°F)
Chemical Resistance	pH 1 to 13 Virtually unaffected by non-oxidizing acids, dilute bases, organic solvents. Should not be used in concentrated or hot sulfuric (> 60%), nitric acids (>10%), or strong bases



- High chemical resistance
- Non-staining
- Non-hardening
- Non-abrasive

InnerLube™

Synthetic/PTFE

Combines Chesterton's synthetic coating yarn and patented InnerLube construction. Offers increased lubrication at start-up and continues to disperse lubrication during operation, resulting in lower operating temperatures and reduced shaft and sleeve wear.

Technical Data	
Materials	Synthetic fibers interbraided with specialized lubricant reservoirs, treated with PTFE and a break-in lubricant
Applications	General water and slurry service
Pressure	14 bar g (200 psig)
Speed	10 m/s (2000 fpm)
Temperature	260°C (500°F)
Chemical Resistance	pH 2 to 12



- Increased lubrication
- Lower operating temperatures
- Non-staining, chemically resistant

477-1T

Carbon/PTFE

A tough, yet pliable, continuous filament carbon yarn packing impregnated throughout with PTFE to provide a non-contaminating, non-staining carbon yarn packing.

Technical Data	
Materials	Carbon yarn coated with PTFE, blocking agent and corrosion inhibitor
Applications	Virtually all pumps and valves, especially tough pulp and paper applications
Pressure	14 bar g (200 psig)
Speed	10 m/s (2000 fpm) 15 m/sec (3000 fpm) when used as a bottom anti-extrusion ring with Chesterton 1400R
Temperature	260°C (500°F)
Chemical Resistance	pH 0 to 14 except strong oxidizers

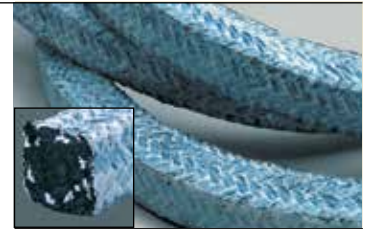

- Non-contaminating, non-staining carbon yarn packing
- Unique inorganic blocking agent stops gas/liquid penetration
- Molybdenum-based corrosion inhibitor prevents stem pitting

412-W

Multi-Service

A synthetic coating yarn with a specially formulated break-in lubricant to prevent failure at start-up and maintain continuous lubrication throughout the break-in process.

Technical Data	
Materials	Synthetic composite yarn with PTFE and break-in lubricants
Applications	Water, brine, mild acids and alkalis, slurries, and knife gate valves
Pressure	17 bar g (250 psig)
Speed	10 m/s (2000 fpm)
Temperature	230°C (450°F)
Chemical Resistance	pH 4 to 10



- Pure white packing
- Superior tensile strength
- Holds twice the PTFE blocking agent of traditional fibers

SLURRY/ABRASIVE

1830

Advanced Expanded Graphite PTFE Packing

Economical packing developed to meet strict specifications in pumps, agitators, mixers, and other rotating equipment.

Technical Data	
Materials	Expanded graphite PTFE filaments
Applications	Wide range of applications
Pressure	22 bar g (320 psig)
Speed	18 m/s (3600 fpm)
Temperature	260°C (500°F)
Chemical Resistance	pH 0 to 14 with exception of strong oxidizers in the 0 to 2 pH range

Applicable Standards and Approvals: BAM



- Excellent chemical resistance
- Low friction, less heat generation, non-abrasive, saves shafts and shaft sleeves
Easy installation and removal
- Low leakage and long life

1830-SSP

Slurry Packing

Designed with a hybrid yarn combining advanced, expanded graphite PTFE yarn with carbon yarn reinforcement that runs through the cross section of the packing for easy extraction.

Technical Data	
Materials	Carbon reinforced expanded graphite PTFE
Applications	Slurry pumps, mineral handling slurries, tailing pumps
Pressure	28 bar g (400 psig)
Speed	18 m/s (3600 fpm)
Temperature	260°C (500°F)
Chemical Resistance	pH 0 to 14 with exception of strong oxidizers in the 0 to 2 pH range



- Developed to meet rigid demands of slurry sealing applications
- Excellent chemical resistance
- Low friction, less heat generation, non-abrasive, saves shafts and shaft sleeves

1740

Anti Extrusion Aramid

An interbraid packing using Kevlar® yarn and lubricated with PTFE and other lubricants to offer combined resistance to pressure, temperature, chemicals, and wear.

Technical Data	
Materials	Kevlar® yarn coated with PTFE
Applications	Aggressive slurries and as an anti-extrusion ring
Pressure	20 bar g (300 psig)
Speed	10 m/s (2000 fpm)
Temperature	260°C (500°F)
Chemical Resistance	pH 4 to 11

Kevlar® is a registered trademark of E.I du Pont de Nemours and Company



- Excellent extrusion resistance in abrasive applications
- Non-staining, non-contaminating
- Non-asbestos, multi-service packing

SuperSet™

Enhanced Packing Sets

Chesterton performance packing sets, in combination with the patented SpiralTrac™ Environmental Controller, reduce flush water consumption and increase equipment service life.

Common Versions	Applications
1730 SuperSet	General service in slurries and clean fluids
1400R / GraphMax™ SuperSet	Worn equipment, high-speed and high-temperature applications
1760 SuperSet	Highly aggressive chemical environments
1830SSP SuperSet	Bauxite slurries, bottom ash pumps, minerals handling pumps, tailings and other slurries



- Reduces flush water consumption
- Increases equipment MTBR
- Reduces shaft sleeve wear

FOOD GRADE

425

Virgin PTFE Food Process Packing

Non-staining PTFE packing certified for use in the food handling industry.

Technical Data	
Materials	Virgin PTFE filament with white oil lubricant
Applications	All types of equipment in the food handling industry including valves, blenders, mixers, pumps, and agitators
Pressure	15 bar g (200 psig) rotating applications 55 bar g (800 psig) valves
Speed	6 m/s (1200 fpm)
Temperature	230°C (450°F)
Chemical Resistance	pH 0 to 14

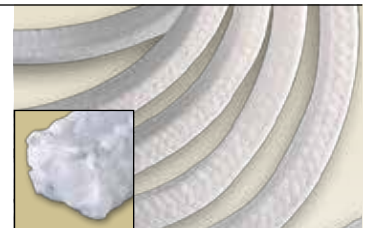

- Complies with USDA requirements for minimal food contact
- Complies with FDA 21 CFR, 178.3620 and 177.1550

1725A

High Performance Food Grade

A white, non-staining, ePTFE packing for use in food processing equipment including pumps, agitators, and mixers.

Technical Data	
Materials	Expanded PTFE with a food grade lubricant
Applications	Chemical and food grade rotating equipment except strong oxidizers and molten alkali metals
Pressure	22 bar g (325 psig)
Speed	9 m/s (1800 fpm)
Temperature	260°C (500°F)
Chemical Resistance	pH 0 to 14



- Meets USDA Requirements for minimal food contact
- Meets FDA Requirements 21 CFR 178.3297, 21 CFR 177.2800, 21 CFR 177.1550
- Completely inert to most materials
- Handles high shaft speeds

SpiralTrac™ is a trademark of EnviroSeal Engineering Products Ltd.

INJECTABLE

CMS2000

Flushless Packing System

An advanced injectable stuffing box leakage control sealant made of high purity, reinforced fiber available in graphite, white, and food grade (FP) non-staining formulations.

Technical Data			
	Advanced, thermally stable fiber with lubricants and high temperature blocking agents, White		
Materials	A combination of fibers and non-settling graphite with high temperature lubricants and blocking agents, Black FDA compliant fibers, lubricants, and blocking agents, FDA		
Applications	Stock pumps, white water pumps, river water pumps, condensate pumps, water treatment pumps, Black and White Rotating equipment applications in the food processing and handling industry, FP		
Pressure	22 bar g (325 psig)		
Speed	10 m/s (2000 fpm), White	8 m/s (1600 fpm), Black	6 m/s (1200 fpm), FP
Temperature	205°C (400°F), White	205°C (400°F), Black	205°C (400°F), FP
Chemical Resistance	pH 1 to 13, White not recommended for oxidizers, fluorine, chlorine trifluoride and related compounds, and molten alkali metals. pH 4 to 13, Black not recommended for oxidizing agents. pH 0 to 14, FP		



- Eliminates flush and reduces leakage to insignificant levels
- Will not score shaft sleeves
- Effective with worn, fretted sleeves
- Never disassemble to repack again

CHEMICAL

1760

Chemical Packing

Strong and dense PTFE fiber packing for chemical applications with the heat dissipating properties of graphite.

Technical Data	
Materials	Graphite coated PTFE yarn with break-in lubricants
Applications	Black liquor pumps, chemical pumps, and agitators
Pressure	17 bar g (250 psig)
Speed	18 m/s (3600 fpm)
Temperature	260°C (550°F)
Chemical Resistance	pH 0 to 14



- Dense braid ensures excellent leakage control and prevents solid embedment
- Excellent chemical resistance
- High shaft speed

1765

White Chemical Packing

Non-staining chemical packing ideally suited for bleach pumps and other rotary applications.



- Non-staining
- Superior chemical resistance
- Low friction for improved speed capability
- Longer packing life

Technical Data

Materials	White expanded PTFE yarn with a special filler
Applications	Bleach pumps, chemical pumps, agitators
Pressure	20 bar g (300 psig)
Speed	10 m/s (2000 fpm)
Temperature	Min -40°C (-40°F), Max 260°C (500°F)
Chemical Resistance	pH 0 to 14 except for Fluorine (F ₂), ClF ₃ and related compounds, and molten alkali metals

MARINE

329

Stern-Lon Flax Packing

Flexible and formable high-quality flax packing that is the most recognized stern tube packing in the marine industry.



- Suitable for marine and paper mill applications
- Graphite free to avoid galvanic corrosion
- Produces little or no shaft wear
- Large sizes need not be hammered into place

Technical Data

Materials	PTFE-impregnated flax with break-in lubricants and fluorocarbon powder
Applications	Stern tubes, rudder posts, shaft bulkhead glands, cold water, jordans, claffins, hydro-finers
Pressure	20 bar g (300 psig)
Speed	5 m/s (1000 fpm)
Temperature	135°C (275°F)
Chemical Resistance	pH 6 to 8

GRAPHITE

GraphMax™

Structurally Reinforced Graphite Packing

Dramatically improves the packing's resistance to extrusion and blow out—one of the limitations with traditional flexible graphite tape packings.

Technical Data	
Materials	Graphite with carbon yarn reinforcement and a high-temperature blocking agent
Applications	Virtually all pumps and valves, including steam service
Pressure	260 bar g (3800 psig)* valves 28 bar g (400 psig) pumps
Speed	17 m/s (3400 fpm)
Temperature	Maximum 650°C (1200°F) steam service Minimum -240°C (-400°F)
Chemical Resistance	pH 0 to 14 except oleum, fuming nitric acid, and aqua regia

*For higher pressure limits consult Chesterton Engineering.



- Exclusive construction for plant-wide use in pumps and valves
- Maintains structural integrity for easy removal
- Carbon fiber reinforced graphite strands provide maximum extrusion resistance and high-pressure capability

1400R

Carbon Reinforced Graphite Packing

Combines the unique sealing properties of flexible graphite with the high strength of carbon fiber.

Technical Data	
Materials	Carbon fiber reinforced flexible graphite packing
Applications	Process pumps, boiler feed pumps, block valves, refiners, agitators, and mixers
Pressure	14 bar g (200 psig) rotating applications 275 bar g (200 psig) valves
Speed	20 m/s (4000 fpm) Min -240°C (-400°F)
Temperature	Max 650°C (1200°F) steam Max 455°C (850°F) oxidizing atmosphere
Chemical Resistance	pH 0 to 14 except oleum, fuming nitric acid, and aqua regia

Applicable Standards and Approvals: BAM



- Flushless packing
- High shaft speed capability
- Passive molybdate corrosion inhibitor
- For use in valves and pumps

Lubricated Carbon

Unique carbon and graphite construction provides plant-wide utility off a single spool.

Technical Data	
Materials	Carbon yarn with graphite and other high-temperature lubricants
Applications	Virtually all pumps
Pressure	35 bar g (500 psig)
Speed	18 m/s (3600 fpm)
Temperature	315°C (600°F) steam
Chemical Resistance	pH 0 to 14 except oleum, fuming nitric acid, aqua regia and fluorine



- High-temperature
- Fast break-in
- Controls leakage with minimal friction
- Reduced leakage and flushing

477-1

Carbon Fiber Packing

A new yarn formulation with superior blocking agents, provides the strength associated with continuous filament carbon fibers, plus greater flexibility.

Technical Data	
Materials	A high quality carbon yarn pump and valve packing lubricated with PTFE.
Applications	Virtually all pumps and valves against most solvents, gases, and other liquids.
Pressure	14 bar g (200 psig)
Speed	10 m/s (2000 fpm) 15 m/s (3000 fpm) when used as anti-extrusion rings with 1400R
Temperature	260°C (500°F)
Chemical Resistance	pH 0 to 14 except with strong oxidizers



- Strong, yet pliable, continuous filament carbon yarn
- Unique inorganic blocking agent stops gas/liquid penetration
- Molybdenum-based corrosion inhibitor prevents stem pitting

Style Two

High-Speed Graphite Packing

High shaft speed, high temperature packing made with a pure quality graphite yarn and multi-temperature break-in lubricants.

Technical Data	
Materials	Graphite yarn with multi-temperature break-in lubricants
Applications	Virtually all pumps and valves
Pressure	21 bar g (300 psig)
Speed	23 m/s (4500 fpm)
Temperature	2760°C (5000°F) non-oxidizing 425°C (800°F) oxidizing
Chemical Resistance	0 to 14 except oleum, fuming nitric acid, aqua regia, and flourine



- Maximum performance universal pump packing
- Self-lubricating, virtually no shaft scoring
- Non-hardening, non-glazing

PLS

Polymer Labyrinth Seal

Unitized, Non-Contacting Seal for Bearing Protection

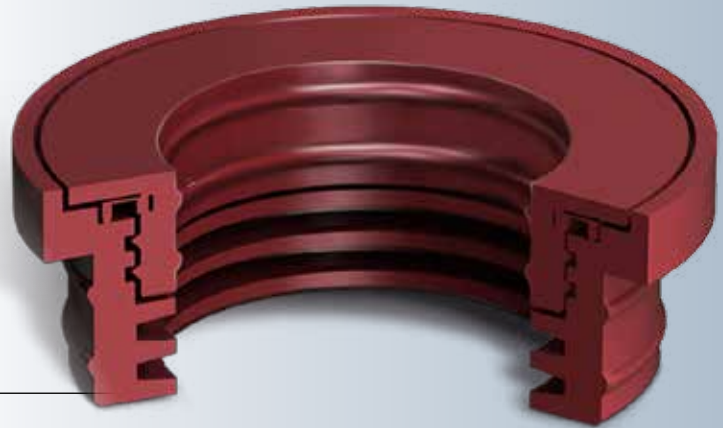

The Chesterton patent-pending Polymer Labyrinth Seal (PLS) is a non-contact bearing seal designed to provide protection for pumps, motors, gearboxes, and other rotating equipment in splash applications. The unique design eliminates fretting caused by conventional lip seals and helps to increase bearing and gearbox life by extending the mean time between equipment repairs.

This unitized labyrinth seal uses Chesterton's exclusive polymer to create a non-contacting 3-piece seal design that includes a rotor, a stator, and a built-in valve with no wearing parts. While in operation, centrifugal force and gravity ensure lubricant is contained within the labyrinth and flows back into the bearing housing, while outside contaminants are excluded and redirected back to atmosphere.

The unique design also incorporates a built-in valve that is activated by shaft rotation which engages during shutdown periods to create a positive seal during idle time, blocking ingress of external contaminants from entering the housing.

Chesterton's Polymer Labyrinth Seal is manufactured from an advanced, durable, maintenance-friendly thermoset polymer compatible with common bearing and gear oils that offers a cost-effective alternative solution to other material options. Each seal is custom manufactured to the exact equipment size needed to maximize performance.

- High-performance, non-contact design, eliminates fretting caused by lip seals
- Keeps lubrication in and seals out external contamination
- Unitized design and durable non-sparking material provide easy, reliable installation
- Available in a variety of configurations to meet plant-wide equipment needs
- Same day shipment availability, minimizing downtime and associated costs
- Standard sizes available for popular equipment, custom sizes available upon request
- IP56 (third party certification) designed to be resistant to dust and water

SPECIFICATIONS

Material (designation)	Size Range mm (inch)	Temperature °C (°F)	Speed* m/s (ft/min)	Eccentricity mm (inch)
Polymer Labyrinth Seal (EU) AWC800	25 to 152 (1 to 6)	-40 to 93 (-40 to 200)	30.5 (6000)	0.75 (0.030)

*Contact engineering for speeds beyond these limits

PRODUCT PROFILES:

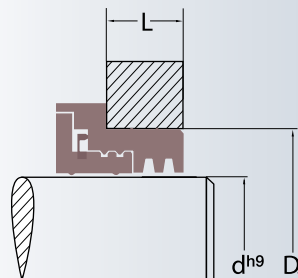

30K

Bearing and Gearbox Protection

Advanced sealing protection technology keeps the lubricant in and the dirt out for long-term sealing.

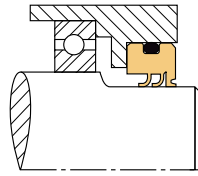

SPECIFICATIONS

Material (combination) (adapters/sealer rings)	Size Range mm (inch)	Temperature °C (°F)	Speed m/s (ft/min)	Pressure MPa (psi)	Recommended use	Mating surface (Rockwell C)
AWC100 (PTFE) Polyimide	20 to 600 (0.787 to 24)	-20 to 149 (-30 to 300)	Up to 20 (4000)	0,07 (10)	Excellent dry Excellent low viscosity No water and steam	≥45
AWC300 (PTFE) Molybdenum & glass					Excellent high viscosity Good dry and good in water	≥55
AWC400 (PTFE) Carbon & graphite					Excellent in water Good dry and low viscosity	≥55
AWC510 (PTFE) Mineral (FDA listed)					Excellent dry Good in water and steam No petroleum liquids	≥45

Performance depends on concurrent conditions including shaft hardness, shaft surface roughness, material, lubrication, temperature, and pressure.

PRODUCT PROFILES:

Applicable standards: ISO3760/ISO3761



30K



30KW



30KSW



30KB



30KBW



- New designs and materials proven to outperform conventional lip seals
- High performance PTFE compounds offer advanced wear and abrasion resistance
- Unique design provides lower friction and decreased shaft wear
- High performance lip seals prevent contaminants from entering housing

33K

Split Bearing and Gearbox Protection

Unitized split seal for bearing and gearbox protection.

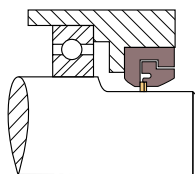

SPECIFICATIONS

Material (adapters/sealer rings)	Size Range* mm (inch)	Temperature °C (°F)	Speed m/s (ft/min)	Pressure MPa (psi)	Recommended use	Mating surface (Rockwell C)
AWC800 Adapters (EU)						
AWC100 (PTFE) Polyimide	25 to 610 (1 to 24)	85 (185)	12,7 (2500)	0,007 (1)	Excellent dry Excellent low viscosity	≥45
AWC300 (PTFE) Molybdenum & glass	25 to 610 (1 to 24)	85 (185)	12,7 (2500)	0,007 (1)	Excellent high viscosity Good dry and good in water	≥55
AWC400 (PTFE) Carbon & graphite	25 to 610 (1 to 24)	85 (185)	12,7 (2500)	0,007 (1)	Excellent in water Good dry and low viscosity	≥55
AWC860 Adapters (EU)						
AWC100 (PTFE) Polyimide	25 to 457 (1 to 18)	121 (250)	12,7 (2500)	0,07 (1)	Excellent dry Excellent low viscosity	≥45
AWC300 (PTFE) Molybdenum & glass	25 to 457 (1 to 18)	121 (250)	12,7 (2500)	0,07 (1)	Excellent high viscosity Good dry and good in water	≥55
AWC400 (PTFE) Carbon & graphite	25 to 457 (1 to 18)	121 (250)	12,7 (2500)	0,07 (1)	Excellent in water Good dry and low viscosity	≥55

Performance depends on concurrent conditions including shaft hardness, shaft surface roughness, material, lubrication, temperature, and pressure.

Applicable standards: ISO3760/ISO3761



- Split design eliminates the need for equipment disassembly
- New design and materials proven to outperform conventional lip seals
- Patented design combines high performance PTFE and polymer materials
- Filled PTFE materials provide high wear and abrasion resistance

R22KN5

Split Rotary Seal

High performance, durable wear resistant polymer material, proven design for slow rotating applications exposed to large shaft run-out.

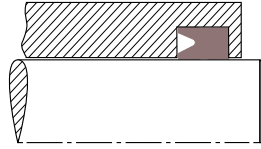

SPECIFICATIONS

Material (designation)	Size Range mm (inch)	Temperature °C (°F)	Pressure MPa (psi)	Speed m/s (ft/min)
AWC700 (FKM)	6 to 152 (1/4 to 6)	-30 to 200 (-20 to 400)	34,5 (5000)	1,5 (300)
AWC800 (EU)	6 to 1400 (1/4 to 55)	-50 to 85 (-60 to 185)	103,5 (15000)	1 (200)
AWC830 (EU)	6 to 254 (1/4 to 10)	-35 to 75 (-30 to 165)	52,0 (7500)	0,9 (185)
AWC850 (EU)	6 to 254 (1/4 to 10)	-50 to 104 (-60 to 220)	103,5 (15000)	0,9 (185)
AWC860 (EU)	6 to 508 (1/4 to 20)	-50 to 120 (-60 to 250)	103,5 (15000)	1,25 (250)

PRODUCT PROFILE:



Depending on the seal height and cross section, the split joint can be interlock arrow cut or butt cut.
*Please contact your Chesterton representative for larger sizes.



- Flexible dynamic lip design for large shaft run-out compensation
- Split configuration simplifies installation
- Robust static lip design allows stack set arrangement and provides stability
- Excellent abrasion-resistance, withstands demanding environments

14K

Restriction Bushing

A robust restriction bushing for rotating equipment.

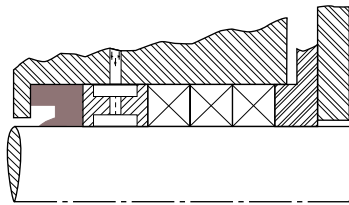

SPECIFICATIONS

Material (designation)	Size Range mm (inch)	Temperature °C (°F)	pH range
AWC520 (PTFE)	25 to 600 (1 to 24)	Up to 200 (400)	0 to 14
AWC800 (EU)	25 to 1400 (1 to 55)	Up to 100 (185)	4 to 10

Applicable standards: ISO 3069

PRODUCT PROFILES:



- Split design simplifies installation
- Prevents particles from entering the stuffing box, extending packing and seal life
- Tapered lip design controls fluid bypass
- Designed for pumps and other rotating equipment such as agitators, mixers, and refiners

30KC

Seal for Viscous Fluids and Powders

High performance, proven cartridge design for sealing powders and viscous fluids.

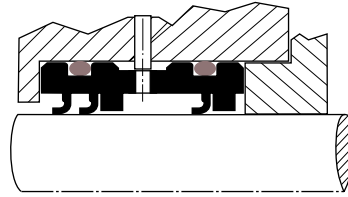

SPECIFICATIONS



Material* (combination) (adapters/sealer rings)	Shaft Size** mm (inch)	Temperature °C (°F)	Speed m/s (ft/min)	Pressure MPa (psi)	Mating surface (Rock- well C)	Surface finish µm Ra (µ inch)	Recommended use***
AWC100 (PTFE) Polyimide	25 to 200 (1 to 8)	-20 to 150 (-30 to 300)	Up to 5 (984)	Up to 1 (150)	45	Dynamic 0,2 to 0,4 (8 to 16) Static 0,4 to 0,8 (16 to 32)	Excellent dry Excellent low viscosity (<2 000 cp) Powders, oil, resins, glues, paints No water or steam
AWC300 (PTFE) Molybdenum & glass					55		Excellent high viscosity (>2 000 cp) Good in dry, water, or steam
AWC400 (PTFE) Carbon & graphite					55		Excellent in water or steam Good dry and low viscosity Powders, asphalt, clay, slurries
AWC510 Mineral (FDA listed)					45		Excellent dry Good in water or steam Chocolate and syrups No petroleum liquids

* Fluoroelastomer O-Rings provided (FDA listed with AWC510).

** Please contact your Chesterton representative for larger sizes.

*** Run-out to 0,15 mm (0,05").

- Outperforms conventional packing, sealing viscosity fluids, and dry powders
- Decreases downtime, easy-to-install, versatile cartridge design
- Improves performance of compression packing, distinct PTFE materials
- Custom-designed cartridges made to equipment dimensions

Asset Protection for Rotating and Associated Equipment

ARC Coatings are in use every day, around the world, in numerous industries protecting process equipment against abrasive wear and metal loss under corrosive and abrasive flow conditions. Your pumps, fans, screws, agitators, and associated structures are valuable assets and protecting them while maintaining their reliable operation, is critical to your plants overall operational efficiency. Our 100% solids, low VOC coatings utilize advanced high molecular weight polymers. We then blend in ceramic and glass reinforcements to handle temperature up to 150°C (350°F) with pH ranges of .1-12.5 in mild to severe abrasive flow conditions.

ARC Metal Coating Systems (MCS) repair rebuild and protect all types of rotating equipment.

ARC Concrete Coating Systems (CCS) protect concrete equipment supports and base plates.

ARC Metal Coating Systems repair, rebuild, and protect all types of industrial process equipment and structures from abrasive, corrosive, and chemically aggressive environments.

- Provide long-term protection
- Extend equipment life
- Cut downtime
- Reduce the need for spare parts
- Simplify maintenance procedures

ARC Concrete Coating Systems repair, rebuild, and protect all concrete structures from abrasive, corrosive, and chemically aggressive environments.

- Provide long-term protection
- Avoid costly structural rebuild
- Reduce safety and environmental hazards
- Simplify maintenance procedures
- Cut downtime



ARC 855

Abrasion Resistant Surface Coating

An advanced liquid, ceramic coating that is formulated to protect equipment from aggressive chemical attack, corrosion, and erosion.

Product Characteristics

Two-coat system
Easily applied by brush or roller
Minimum thickness of 250 µm (10 mils) per coat

Applications

Fans and housings
Pump casings and impellers
Screws



- Improves fluid flow efficiency
- Extends equipment life
- Cuts downtime
- Reduces the need for spare parts
- Certified to WRAS (BS6920) drinking water standard up to 55°C (131°F)

Technical Data

Dry Temperature (Min/Max)	-29°C (-20°F) to 120°C (250°F)
Wet Temperature (Min/Max)	-29°C (-20°F) to 65°C (150°F)
Tensile Adhesion - kg/cm ² - MPa (psi)	352.7 kg/cm ² (34.6 MPa) 5,020 psi
Salt Fog	>10000 hrs
Available Sizes	.75 l, 1.5 l, 5 l, 16 l

ARC 858

Abrasion Resistant Faring Coating

An advanced, trowelable ceramic coating for the repair and resurfacing of all metal surfaces subjected to erosion, corrosion, and chemical attack.

Product Characteristics

Applied by trowel or spatula
Normally applied at a thickness of 1,5 mm (60 mils) or more

Applications

Pump casings and impellers
Fans and housings
Pipe elbows
Screws



- Rebuilds damaged equipment
- Repairs and smooths pitted surfaces
- Able to be top coated with other ARC Coatings

Technical Data

Dry Temperature (Min/Max)	-29°C (-20°F) to 160°C (320°F)
Wet Temperature (Min/Max)	-29°C (-20°F) to 70°C (160°F)
Tensile Adhesion - kg/cm ² - MPa (psi)	478.5 kg/cm ² (47 MPa) 6810 psi
Available Sizes	250 g, 940 ml, 1.5 l, 5 l, 16 l

ARC HT-T, HT-S

HT-T—Spark-Testable, High-Temperature, Abrasion Control Compound.

HT-S—Spark-Testable, High-Temperature, Abrasion Control Liquid.

An advanced ceramic coating that is formulated to protect equipment from corrosion and erosion in elevated temperature immersion of aqueous solutions.



Product Characteristics

HT-T – Applied by trowel at a nominal thickness of 900 to 1150 µm (35 to 45 mils) by trowel or plastic applicator
HT-S – Easily applied by spray, brush, or roller
 Minimum thickness of 250 µm (10 mils) per coat

Applications

Hydrocyclones
 Pump volutes and impellers
 Condensate pumps
 Offshore equipment

- Extends equipment life
- Spark testable for pinhole-free verification
- Reduces downtime
- Cures in service

Technical Data	
Dry Temperature HT-T (Min/Max)	-29°C (-20°F) to 150°C (302°F)
Wet Temperature HT-T (Min/Max)	-29°C (-20°F) to 110°C (230°F)
Dry Temperature HT-S (Min/Max)	-29°C (-20°F) to 175°C (347°F)
Wet Temperature HT-S (Min/Max)	-29°C (-20°F) to 150°C (302°F)
Tensile Adhesion - kg/cm ² - MPa (psi)	Greater than 140 - 14 (2000)
Available Sizes	5 l, 16 l

COATINGS FOR CORROSION, EROSION, AND CHEMICAL ATTACK FOR METALS

ARC S1 PW

General Purpose, Sprayable, Corrosion Protection Coating

An advanced, liquid coating formulated to protect metal surfaces from corrosion and chemical attack.



Product Characteristics

ARC S1 PW
 Low viscosity, brush, roll or spray applied barrier coatings
 Certified to NSF 61 cold water service
 Minimum thickness per coat is 250µm (10 mil)

Applications

Pumps
 Valves
 Fittings
 Tanks
 Structural steel

- Low permeability provides long-term protection
- Spark testable for pinhole-free verification
- Sprayable viscosity for rapid installation

Technical Data	
Dry Temperature (Min/Max)	-29°C (-20°F) to 62°C (144°F)
Wet Temperature (Min/Max)	-29°C (-20°F) to 52°C (125°F)
Tensile Adhesion (metal) - kg/cm ² - MPa (psi)	Greater than 140 - 14 (2000)
Salt Fog	>10000 hrs
Available Sizes	5 l, 16 l



ARC S2

Ceramic-Reinforced, Sprayable, Erosion-Resistant Coating

An advanced, liquid ceramic reinforced coating for the protection of all metal surfaces subject to erosive, corrosive, and severe fluid flow conditions.

Product Characteristics

Two-coat system
Easily applied by spray, brush, or roller
Minimum thickness of 250 µm (10 mils) per coat

Applications

Fans and housings
Cooling water systems
Base Plates
Pump and valve assemblies
Pipe coatings



- Improves fluid flow efficiency
- Extends equipment life
- Sprayable viscosity for rapid installation
- Spark testable for pinhole-free verification
- Certified to WRAS (BS6920) drinking water standard

Technical Data

Dry Temperature (Min/Max)	-29°C (-20°F) to 80°C (175°F)
Wet Temperature (Min/Max)	-29°C (-20°F) to 52°C (125°F)
Tensile Adhesion - kg/cm ² - MPa (psi)	Greater than 140 - 14 (2000)
Salt Fog	>20000 hrs
Available Sizes	1125 ml (cartridge), 1.5 l, 5 l, 16 l

ARC S4+

100% Solids, Mineral-Reinforced, Epoxy Novolac, Acid Resistant Coating

An advanced, liquid polymer coating formulated to protect equipment from extreme chemical attack and corrosion.

Product Characteristics

Two-coat system
Easily applied by spray, brush, or roller
Minimum thickness of 375 µm (15 mils) per coat

Applications

Fans and housings
Acid Transfer Pump
Base Plates
Reactor Agitators



- Provides long-term protection
- Low permeability for immersion conditions
- Sprayable viscosity for rapid installation
- Spark testable for pinhole-free verification

Technical Data

Dry Temperature (Min/Max)	-29°C (-20°F) to 150°C (300°F)
Wet Temperature (Min/Max)	-29°C (-20°F) to 60°C (140°F)
Tensile Adhesion - kg/cm ² - MPa (psi)	330 kg/cm ² (32.4 MPa) 4700 psi
Salt Fog	>10000 hrs
Available Sizes	1125 ml (cartridge), 5 l, 16 l

THIN FILM COATINGS FOR CONCRETE

ARC CS2

General Purpose, Thin Film, Novolac Blend, Epoxy Coating

Thin film, advanced coatings that are formulated to protect concrete surfaces, CS2 is used for mild chemical attack.

Product Characteristics

Easily applied by notched squeegee, brush roller, or spray equipment
 Can be applied to damp concrete
 High gloss surface
 Non-Shrinking, no solvents, 100% solids
 Minimum thickness of 250 to 375 µm (10 to 15 mils) per coat
 Colors: Grey

Applications

Base plates
 Pump bases
 Equipment bases



- Provides long term protection
- Avoids costly structural rebuild
- Reduces safety hazard caused by damaged concrete

Technical Data

Dry Temperature (Min/Max)	-29°C (-20°F) to 80°C (175°F)
Wet Temperature (Min/Max)	-29°C (-20°F) to 52°C (125°F)
Compression Strength - kg/cm ² - MPa (psi)	680 - (9650)
Tensile Adhesion to Concrete - kg/cm ² - MPa (psi)	>28 kg/cm ² (2.8 MPa) 400 psi
Available Sizes	16 l

ARC CS4

Highly Chemically Resistant, 100% Novolac Resin, Epoxy Coating

Thin film, advanced coatings that are formulated to protect concrete surfaces, CS4 is used for harsh chemical attack.

Product Characteristics

Easily applied by notched squeegee, brush roller, or spray equipment
 Can be applied to damp concrete
 High gloss surface
 Non-Shrinking, no solvents, 100% solids
 Minimum thickness of 250 to 375 µm (10 to 15 mils) per coat
 Colors: Red

Applications

Base plates
 Pump bases
 Equipment bases



- Provides long term protection
- Avoids costly structural rebuild
- Reduces safety hazard caused by damaged concrete

Technical Data

Dry Temperature (Min/Max)	-29°C (-20°F) to 80°C (175°F)
Wet Temperature (Min/Max)	-29°C (-20°F) to 40°C (105°F)
Compression Strength - kg/cm ² - MPa (psi)	970 - (13750)
Tensile Adhesion to Concrete - kg/cm ² - MPa (psi)	>28 kg/cm ² (2.8 MPa) 400 psi
Available Sizes	5 l, 16 l

ARC 890/897

890— Severe Slurry Wear Coating

897—Moderate Slurry Wear Coating

Advanced, ceramic-reinforced coating for the repair and protection of all metal surfaces subjected to moderate to severe abrasion.

Product Characteristics	Applications	
High volumetric ceramic particle loading	Separators and cyclones	Slurry pumps
Applied by trowel or plastic applicator tool	Hoppers/chutes	Pipe elbows
890 - Applied at a nominal thickness of 6 mm (240 mil) or more	Coal pulverizers	ID/FD fans
897 - Applied at a nominal thickness of 3 mm (120 mil) or more	Hydro pulpers	Screws
	Agitators	

Technical Data	
Dry Temperature (Min/Max)	-29°C (-20°F) to 205°C (400°F)
Wet Temperature (Min/Max)	-29°C (-20°F) to 95°C (205°F)
Tensile Adhesion - kg/cm ² - MPa (psi)	238 kg/cm ² (23 MPa) 3390 psi
Available Sizes	ARC 890: 1.5 l, 5 l, 16 l ARC 897: 1.5 l, 5 l, 16 l



- Reduces the need for spare parts
- Simplifies maintenance procedures
- Extends equipment life
- Improves safety by reducing hotwork

ARC I BX1

Impact and Wear Resistant Epoxy Coating

I BX1 is a urethane modified amine cured epoxy coating, highly reinforced with ceramic beads and flakes for resistance to severe sliding abrasion where impact forces or rapid vibration is a concern.

Product Characteristics	Applications
High volumetric ceramic particle loading	Slurry pumps
Applied by trowel or plastic applicator tool	Pipes and pipe elbows
Applied at a nominal thickness of 6 mm (240 mil)w or more	Agitators
	ID/FD format

Technical Data	
Dry Temperature (Min/Max)	-29°C (-20°F) to 205°C (400°F)
Wet Temperature (Min/Max)	-29°C (-20°F) to 95°C (205°F)
Tensile Adhesion - kg/cm ² - MPa (psi)	238 kg/cm ² (23 MPa) 3390 psi
Available Sizes	20 kg, 12 x 20 kg



- High impact resistance
- Reduces the need for spare parts
- Simplifies maintenance procedures
- Extends equipment life
- Improves safety by reducing hotwork

Performance and Productivity

Chesterton offers products and total system solutions for production process, facility, and maintenance needs.

- *Lubricants and greases*
- *Maintenance specialties*
- *Cleaners and degreasers*
- *Metalworking fluids and corrosion control*

State-of-the-art technologies, environmentally acceptable alternatives and strict quality processes contribute to fulfilling the customers' expectations:

- Increased productivity
- Lowered costs
- Reduced disposal and labor costs

In partnership with our worldwide distribution channels and factory-trained local specialists, Chesterton offers superior value, outstanding customer service, technical support, and delivery.

In these pages, you will find an overview of our products. For in-depth, individual product information, ask your local Chesterton Specialist.



610/610MT Plus/610HT

Synthetic Lubricating Fluid—High-Temperature Service

Premium quality, 100% synthetic fluid that cleans as it lubricates over a wide temperature range of -25°C to 270°C (-13°F to 518°F).

Product Characteristics

Low evaporation
 Low carbonizing
 High detergency—self-cleaning
 E.P. additives increase load carrying ability
Available Container Sizes: Aerosol (610 only),
 3,8 l (610/610HT only), 20 l, 208 l

Applications

Equipment operating at elevated temperatures
 Refrigerated areas
 Severe environments
 Oven and high-temperature chains
 Bearings
 Gearboxes

NSF Registered

636FG is a Food Grade version of 610MT Plus.

610 Primary Viscosities - ISO VG 68 - 610, ISO VG 220 - 610MT Plus, ISO VG 460+ - 610HT



- Reduces lubricant consumption
- Reduced equipment cleaning and downtime
- Reduces energy consumption
- Increases equipment life

GREASES

615

HTG NLGI #1, HTG NLGI #2

High-performance, corrosion-inhibited grease with outstanding extreme pressure capabilities and excellent water washout resistance.

Temperature limit -40°C (-40°F) to 204°C (400°F)

Product Characteristics

Superior water resistance
 Excellent corrosion protection
 Compatible with most popular greases
 Exceptional shear resistance
 Anti-oxidants prevent hardening
 QBT™ Quiet Bearing Technology
Available Container Sizes: 400 g, 18 kg,
 55 kg, 181 kg

Applications

High water, temperature environment plants including:
 Pulp and paper mills
 Mining operations
 Steel, aluminum, and metal processing
 Marine
 Power
 Water and wastewater

NSF Registered



- Extends bearing life
- Reduces downtimes
- Increases productivity
- Reduces grease consumption

635 SXC

High-performance, corrosion-inhibited grease with outstanding extreme pressure capabilities and excellent water washout resistance. 635 is synthetic based and offers superior high-temperature stability and resistance to steam and corrosive chemicals. Temperature limit -40°C (-40°F) to 240°C (464°F)

Product Characteristics

High load carrying capability
 High-temperature stability
 Superior water washout resistance
 Excellent corrosion protection
Available Container Sizes: 400 g, 18 kg,
 55 kg, 180 kg

Applications

High water, temperature environment plants including:
 Pulp and paper mills
 Mining operations
 Steel, aluminum, and metal processing
 Marine
 Power
 Water and wastewater



- Extends bearing life
- Reduces downtimes
- Increases productivity
- Reduces grease consumption

LUBRICANT DISPENSERS

Lubri-Cup™ EM

Automatic single-point lubricator dispenses Chesterton grease to critical areas, eliminating over- and under-greasing.

Product Characteristics

Microprocessor-controlled, "pulse" delivery system
 Programmable—operates up to 12 months
 Replaceable service packs
 Lubricates up to 8 bearings—up to 6 m (19 ft) away
 Sealed microprocessor

Applications

All Industries Including:
 Pulp and paper mills
 Mining operations
 Metal fabrication
 Steel mills
 Marine

Versions Available

Lubri-Cup EM	Battery operated
Lubri-Cup EM SP	Machine synchronized and externally powered (DC power and AC power)
Lubri-Cup EM Service Pack	Grease fluid service pack for Lubri-Cup EM units (need to purchase with dispenser)



- Reliable lubrication system
- User-friendly
- Cost-effective

Lubri-Cup™ OL 500 Oiler

Automatic lubricator dispenses Chesterton oils to chains and other critical areas.

Product Characteristics

Microprocessor-controlled, "pulse" delivery system
 Programmable—operates up to 12 months
 Refillable
 Lubricates up to 4 points
 Sealed microprocessor

Applications

All Industries Including:
 Pulp and paper mills
 Saw mills
 Mining operations
 Steel mills
 Food, pharmaceutical, beverage industries
 General industry

Versions Available

Lubri-Cup 500cc oiler	Battery operated
Lubri-Cup 500cc oiler	Machine synchronized and externally powered (DC power)
Lubri-Cup 500cc oiler	Machine synchronized and externally powered (AC power)



- Environmentally-friendly, refillable container
- User-friendly with a large LCD
- Cost-effective

Lubri-Cup™ 250cc/VG Mini

Automatic single-point lubricator dispenses Chesterton grease to critical areas, eliminating over- and under-greasing.

Product Characteristics

A compact, convenient and sturdy design that is simple to install and operate
 Preset dispensing rates—1, 3, 6, 9, 12 months
 Remote operation—up to 0,3 m (1 ft)
 Electrochemical operation (Nitrogen gas)
 Sealed microprocessor
 Ability to turn on and off

Applications

All Industries Including:
 Mining and ore processing
 Power
 Pulp and paper
 Water and wastewater
 Steel and metal processing



- Cost-effective
- Transparent container for lubricant inspection
- Reliable lubrication system

785 & 785 FG

Parting Lubricant

The “new generation” anti-seize compound contains a blend of ultra fine, inorganic solid lubricants in a non-carbonizing, ashless synthetic carrier. Withstands severe temperature and pressure conditions.

Product Characteristics

Eases disassembly up to 1204°C (2200°F)
 Fills in microscopic voids
 No toxic-heavy metals
 For extreme pressures up to
 4730 kg/cm² (67570 psi)
Available Container Sizes:
 785: 250 g, 500 g, Aerosol, 24 kg
 785FG: 200 g, 500 g

NSF Registered

Applications

Covers all industries
 Bolts
 Screws
 Studs
 Pipe threads
 Press fits
 Pump sleeves
Note: FG designates a Food Grade Product



- Lubricates for assembly and disassembly
- Protects against corrosion
- No need for torque tension recalculation

783

ACR

783 combines high performance industrial anti-seize performance with extreme corrosion protection and water washout resistance. 783 is ideal where the primary cause of bolt seizure is corrosion.

Product Characteristics

Eases disassembly up to 900°C (1652°F)
 Fills in microscopic voids
 No toxic heavy metals
 For extreme pressure
 up to 8928 kg/cm² (127000 psi)
 Safer than traditional metallic based anti-seizes
Available Container Sizes: 250 g, 500 g, 20 l

Applications

Covers all industries
 Bolts
 Screws
 Studs
 Pipe threads
 Press fits
 Pump sleeves



- Extreme corrosion protection and water washout resistance
- Lubricates for assembly and disassembly

725

Nickel Anti-Seize Compound

A high-performance, nickel based anti-seize. Combines the extreme pressure, corrosion resistant anti-seize abilities of colloidal nickel in an oil suspension that can withstand temperatures up to 1425°C (2597°F).

Product Characteristics

Ultra fine particles
 Guards against galling and corrosion
 Protects against self-welding
 Withstands extreme pressure
 Up to 1425°C (2597°F)
Available Container Sizes:
 725: 250 g, 500 g, Aerosol, 20 l
 772: 500g

Applications

Covers all industries
 Mechanical assembly of:
 bolts, studs, flanges, press fits,
 valve stems, pump sleeves, screws,
 bushings, gaskets, bearings
Meets MIL-A-907D
 NSF Registered
 772 Premium Anti-Seize—Nuclear certifiable



- Lubricates for assembly and disassembly
- Protects against corrosion
- No need for torque tension recalculation

PENETRATING OILS

706

Rustsolvo®

High-quality, fast acting, penetrating oil that reaches inaccessible areas and frees frozen nuts, bolts, and fittings without damaging the base metal.

Product Characteristics

Safe on plastic and painted surfaces
 Contains no glycols, alcohols, DMSO (dimethyl sulfoxide) or chlorinated solvents
 Pleasant odor
 Creeps into microscopic spaces
Available Container Sizes: 1 l, 20 l, 208 l

NSF Registered

Applications

Use on all corroded or seized threaded assemblies in the harshest industrial environments



- Single function—optimizes performance
- Fast acting
- Safe to use

723 & 723 FG

Sprасolvo®

Fast acting, penetrating oil in a convenient, non-flammable propellant aerosol can. Excellent for hard to reach areas where rust, tar, grease, and dirt may prevent easy removal of nuts, bolts, and fittings.

Product Characteristics

Pinpoint spray
 Safe on plastic and painted surfaces
 Contains no acids or chlorinated solvents
 Creeps into microscopic spaces
Available Container Sizes: Aerosol

NSF Registered

723FG—Conforms to FDA standard
 21CFR 172.884, 178.3620, 178.3650

Applications

Use on all corroded or seized threaded assemblies in the harshest industrial environments
Note: FG designates a Food Grade Product



- Single function—optimizes performance
- Fast acting
- Safe to use

THREAD SEALING

800

GoldEnd® Tape

Heavy-duty, high density, tear resistant, moldable, dry PTFE sealant tape for use on metal or plastic threads, pipes, or bolts.

Product Characteristics

-240°C (-400°F) to 260°C (500°F)
 Seals tightly and opens easily
 Non-aging, non-hardening
 Chemically resistant
 Requires fewer wraps
 Resists tearing and breakage
 Won't clog lines

Applications

Liquids: Steam, water, salt water, air, fuels, refrigerants, acids, alkalis, all solvents
Gases: Hydrogen, ammonia, oxygen, propane, butane, nitrogen
Other: Pneumatic and hydraulic fittings up to 690 bar (10 000 psi)

UL listed. Meets MIL-T-27730A. NSF Registered. DVGW approval No. 96.01e907. Acceptable for oxygen use



- Seals with 1 ½ to 2 wraps—virtually all chemicals
- Adjustable by 90°, no leakage
- No waste

860

Moldable Polymer Gasketing

Two-part, extrudable gasketing material allows for the creation of ultra-thin gaskets in any size, any shape. Never sticks to surfaces.

Product Characteristics

Resistance to oils, water, chemicals, and solvents
 Never sticks to surfaces
 Fills voids and scratches, up to 6 mm (1/4 inch) deep
 Remains elastic
 Temperatures up to 260°C (500°F)
 Steam to 6,8 kg/cm² (100 psi) and 170°C (338°F)

Applications

For sealing complex mechanical assemblies
 Gear boxes, inspection covers, bearing housings, fittings, oil sumps and reservoirs, turbine casings, electrical boxes, vacuum systems
NSF Registered. Conforms to FDA standard 21CFR 175.300 and 177.2600. Caution: Not for use in contact with concentrated acids or hot concentrated caustics



- Economical
- Creates gaskets any size and shape
- Ease of application—speeds up maintenance

803

Industrial and Marine Solvent II

A powerful, non-solvent based degreaser. Its advanced surfactant technology offers maximum efficiency in soil removal, especially applications where solvent use is required.

Product Characteristics

Cleaning dust, dirt, carbon black, petroleum based oils
 Phosphate-free, no EDTA or toxic solvents
 No irritating fumes
 Compatible with pressure washers and steam cleaners
Available Container Sizes: 3,8 l, 20 l, 208 l, 1000 l

Applications

Covers all industries
 Cleaning production equipment, facilities, floors, walls and steel structures

NSF Registered
Caution: Should not be used on aluminum or metals sensitive to high alkalinity. When using on painted surfaces, test small area for compatibility.



- Cost-effective—highly concentrated—dilute with water to use
- Strong, fast acting
- Improves worker safety
- Biodegradable

360

Phosphate-Free Cleaner

Especially effective on animal fats and vegetable oils for the food industry. A versatile, industrial cleaner for environmentally sensitive areas.

Product Characteristics

Highly effective on animal fat and vegetable oil
 High stable foam
 Solvent-free
Available Container Sizes: 20 l, 208 l, 1000 l

Applications

Food, pharmaceutical, and beverage industry
 Meat and poultry plants
 Bottling, canning, packaging machines
Wastewater treatment
 Floors, pump stations
 Sludge and fungi removal
Marine
 Decks, hulls, bilges
Industrial
 Floors, walls, tiles, concrete
 Machines

NSF Registered

Caution: Do not use on aluminum



- Cost-effective—highly concentrated—dilute with water to use
- Strong, fast acting
- Improves worker safety
- Environmentally friendly—biodegradable

820

KPC

Balances powerful performance with environmental compliance and worker safety—the ideal choice for process degreasing.

Product Characteristics

Effective on:

- Oil deposits
- Soot and exhaust residue
- Lubricants and metal working fluids
- Animal and vegetable fats
- Low residue
- No phosphates, harsh alkalis or EDTA

Available Container Sizes: 20 l, 208 l, 1000 l

NSF Registered

Applications

Ideal for manual, dip tank, and ultrasonic cleaning
 Effective for dip tank cleaning when heated to 82°C (180°F)



- Cost-effective—highly concentrated—dilute with water to use
- Strong, fast acting, yet moderate pH
- Improves worker safety
- Environmentally friendly—biodegradable

235

SSC

Powerful cleaner removes oily and greasy deposits, waxes, loose paint, and heavy soils. Specially formulated for steam cleaning equipment.

Product Characteristics

- Additives retard scale build-up and clogging of steam cleaning equipment
- Contains strong alkalis, emulsifiers, and surfactants
- No irritating fumes

Available Container Sizes: 20 l, 208 l

NSF Registered

Caution: Should not be used on aluminum or metals sensitive to high alkalinity. When using on painted surfaces, test small area for compatibility.

Applications

General
 Concrete
 Masonry
 Equipment (all types)



- Cost-effective—highly concentrated—dilute with water to use
- Strong, fast acting
- Improves worker safety by removing slippery surfaces
- Biodegradable

338

Super Rust Remover

Removes rust from ferrous metals, corrosion from aluminum, brightens copper, brass, stainless steel, and zinc—quickly and safely.

Product Characteristics

Removes metal oxide layer
Brightens non-ferrous metals
Leaves metal paint ready
Rinses clean with water
Short term corrosion protection
Available Container Sizes: 20 l, 208 l

Applications

General
Metal prefinishing of machined parts and metalwork
Maintenance
Restores rusted inventories, nuts/bolts
Threaded assemblies, internal corrosion
Shafts, cast housings



- Cost-effective—highly concentrated—dilute with water to use
- Inhibited to protect base metals
- Biodegradable

346

Descaler and Chemical Cleaner

Strong, acid based, multi-use liquid, formulated with metal protecting inhibitor for a wide range of applications.

Product Characteristics

Dissolves rust and scale while protecting base surface
Concentrated hydrochloric base and additives
Available Container Sizes: 20 l, 208 l

Applications

Steam boiler tubes
Condenser water systems
Water circulating equipment
Etches concrete



- Cost-effective—highly concentrated—dilute with water to use
- Saves on labor, maintenance costs, and fuel consumption in heat transfer equipment
- Inhibited to protect base metals
- Biodegradable

NSF Registered

Caution: Not effective on grease, oil, and common soil.
Not for use on aluminum, painted enamel, stainless steel, or decorative metals.

274

Industrial Degreaser

A hard surface degreaser for industrial and marine environments.

Product Characteristics

Dissolves petroleum oil, grease, tar and other inorganic soils
Low odor, aromatic content
Does not attack metal, most paints, and plastics
Fast, penetrating action
Available Container Sizes: Aerosol, 20 l, 208 l

Applications

Maintenance shops
Dip tanks
Hard surfaces
Machined parts
Recirculating and agitated parts washers



- Cost-effective
- Low evaporation, long life-time, reduced consumption
- Improve worker safety
- High flash point

NSF Registered

CORROSION CONTROL

775

Moisture Shield

An efficient, clear, moisture-displacing and anti-corrosion protective film that protects metal parts and equipment for months.

Product Characteristics

Transparent film
 Excellent corrosion protection
 Penetrates fine tolerances
 High dielectric strength
 Protects new metal from corrosion
Available Container Sizes: Aerosol, 20 l, 208 l

Applications

Parts in process, transit, or storage
 Electrical systems
 Marine industry
 Drying out of wet electrical parts
Note: Where long term protection is desired use Chesterton's 740 Heavy Duty Rust Guard

Conforms to MIL-C-16173D corrosion preventative, Grade 3



- Short term corrosion protection
- Easily removable with Chesterton's water-based or solvent-based cleaners

740

Heavy Duty Rust Guard

This long-term, corrosion preventative coating provides heavy-duty metal protection for all areas constantly exposed to humidity and corrosive fumes—without critical surface preparation.

Product Characteristics

Self-healing, if scratched
 Transparent brown
Available Container Sizes: Aerosol, 3,8 l, 20 l, 208 l

Applications

Metal tools
 Parts in process
 Parts in storage
 Pumps
 Indoor structural steel
Note: Product can be easily removed with Chesterton's 276 Electronic Component Cleaner or 274 Industrial Degreaser

Conforms to MIL-C-16173D, Grade 1 and 4



- Provides up to two years corrosion protection under sheltered outdoor conditions
- Does not peel or flake
- Excellent resistance to acid, alkali, and salt air fumes

NSF Registered Products, A.W. Chesterton Company

This table provides general guidelines. For the most current listings and full descriptions of the category codes please visit www.NSF.org/usda/psnclists.asp.

218 HDP	133943	A1	636 FG SLF220	147202	H1
235 SSC	133964	A4	651 Detergent Lubricating Oil (aerosol)	133928	H2
273 Electric Motor Cleaner	133975	K2	651 Detergent Lubricating Oil (bulk)	133946	H2
273 Electric Motor Cleaner (aerosol)	133976	K2	652 Pneumatic Lubricant and Conditioner	133944	H2
274 Industrial Degreaser	133955	C1, K1, K2	660 Silicone Lubricant (aerosol)	133970	H1
274 Industrial Degreaser (aerosol)	133949	C1, K1, K2	660 Silicone Lubricant (bulk)	133932	H1
276 Electronic Component Cleaner (aerosol)	133973	K2	662 FG Barrier Fluid 22	143837	H1
276 Electronic Component Cleaner (bulk)	133974	K2	690 FG Lubricant (aerosol)	133933	H1
277 Metal Surface Degreaser (aerosol)	134008	C1, K1	690 FG Lubricant (bulk)	133969	H1
277 Metal Surface Degreaser (bulk)	134007	C1, K1	706 Rustsolvo®	133942	H2
279 PCS	134012	K2	710 Anti-Seize Compound (bulk)	133958	H2
292 Precision Degreasing Solvent	134003	K1, K2, K3	715 Spraflex®	133938	H2
292 Precision Degreasing Solvent (aerosol)	134004	K1, K2, K3	715 Spraflex® (aerosol)	133934	H2
294 CSD	143867	C1, K1, K3	715 Spraflex® Gold	133930	H2
346 Descaler and Chemical Cleaner	133962	A3	715 Spraflex® Gold (aerosol)	133931	H2
3500 Valvelon®	134013	P1	723 FG Sprasolvo®	134006	H1
360 Phosphate-Free Cleaner	133961	A1, A4	723 Sprasolvo®	133939	H2
390 Cutting Oil (aerosol)	134947	H2, P1	725 Nickel Anti-Seize Compound	133959	H2
395 Tapping Lubricant	133935	H2	730 Spragrip®	133947	P1
438 PTFE Coating (aerosol)	133950	H2	775 Moisture Shield (aerosol)	134015	H2
601 Chain Drive Pin and Bushing Lubricant (aerosol)	133927	H2	785 FG Parting Lubricant	132237	H1
601 Chain Drive Pin and Bushing Lubricant (bulk)	133979	H2	785 Parting Lubricant	133960	H2
610 Synthetic Lubricating Fluid (aerosol)	133972	H2	787 Sliding Paste	133956	H2
610 Synthetic Lubricating Fluid (bulk)	133971	H2	800 GoldEnd® Tape	134016	H1, P1
615 High Temperature Grease	133940	H2	801 Industrial and Marine Solvent	133965	A1, A4, A8
615 HTG #1	133941	H2	803 Industrial and Marine Solvent II	133966	A1
622 White Grease	133929	H1	860 Moldable Polymer Gasketing (cartridge)	134017	P1
625 CXF Corrosion Resistant, Extreme Pressure Food Grade Grease	138414	H1	860 Moldable Polymer Gasketing Curing Agent	134018	P1
629 High Temperature White Grease	133936	H1	900 GoldEnd® Paste	133957	H2, P1
630 SXCF	142462	H1	KPC 820	133963	A1
630 SXCF Synthetic Extreme Pressure Corrosion Resistant Food Grade Grease	138415	H1			

Elgiloy® is a registered trademark of Elgiloy Specialty Metals.
 Kevlar® is a registered trademark of E.I du Pont de Nemours and Company
 Monel® is a registered trademark of American Special Metals, Corporation.
 NSF® is a registered trademark of NSF International.
 SpiralTrac™ is a trademark of EnviroSeal Engineering Products Ltd.

CHESTERTON® GoldEnd®, Multi-Lon®, Rustsolvo®, Spraflex®, Spragrip®, Sprasolvo®, and Valvelon® are registered trademarks of A.W. Chesterton Company.
 180™, 280™, 442C™, ChemLast™, GraphMax™, InnerLube™, Intelli-Flow™, Lubri-Cup™, QBT™, Self-Centering Lock Ring™, and SuperSet™ are trademarks of A.W. Chesterton Company.

All statements in this catalog pertaining to pressure, chemical compatibility, temperature, and service ratings are based on general service experience. Because of the wide variety of applications of our products, the broad range of products available, and the wide range of equipment conditions encountered, together with the unpredictable human factors involved in the installation of these products by the ultimate user, you should not follow recommendations shown without specific prior service experience or consultation with an authorized Chesterton representative.

Specific data on materials, construction methods, installation, and troubleshooting procedures are subject to change without notice.

Performance is closely associated with the process operating conditions and equipment conditions. Technical data reflects results of laboratory tests and is intended to indicate general characteristics only. A.W. CHESTERTON COMPANY DISCLAIMS ALL WARRANTIES EXPRESSED, OR IMPLIED, INCLUDING WARRANTIES OF MERCHANTABILITY AND FITNESS FOR A PARTICULAR PURPOSE OR USE. LIABILITY, IF ANY, IS LIMITED TO PRODUCT REPLACEMENT ONLY.



Global Solutions, Local Service

Since its founding in 1884, the A.W. Chesterton Company has successfully met the critical needs of its diverse customer base. Today, as always, customers count on Chesterton solutions to increase equipment reliability, optimize energy consumption, and provide local technical support and service wherever they are in the world.

Chesterton's global capabilities include:

- Servicing plants in over 100 countries
- Global manufacturing operations
- More than 500 Service Centers and Sales Offices worldwide
- Over 1200 trained local Service Specialists and Technicians

Visit our website at www.chesterton.com



Chesterton ISO certificates available on
www.chesterton.com/corporate/iso

Technical data reflects results of laboratory tests and is intended to indicate general characteristics only. A.W. Chesterton Company disclaims all warranties express, or implied, including warranties of merchantability and fitness for a particular purpose. Liability, if any, is limited to product replacement only. Any images contained herein are for general illustrative or aesthetic purposes only and are not intended to convey any instructional, safety, handling or usage information or advice respecting any product or equipment. Please refer to relevant Safety Data Sheets, Product Data Sheets, and/or Product Labels for safe use, storage, handling, and disposal of products, or consult with your local Chesterton sales representative.

© 2016 A.W. Chesterton Company

® Registered trademark owned and licensed by A.W. Chesterton Company
in USA and other countries, unless otherwise noted.

Distributed by:



A.W. Chesterton Company
860 Salem Street
Groveland, MA 01834 USA

Telephone: 781-438-7000
Fax: 978-469-6528
www.chesterton.com

Form No. EN23537
Rotary Equipment Catalog – English
2/16